

Product Features

- Adjustable water temperature
- Soft aerated water flow
- Easy grip wide handle
- Smooth handle rotation
- Tall version to match sit-on countertop basin
- High corrosion & tarnish resistant
- Easy maintenance

Product Specification

- Installation type : Deck mounted
- Dimension : 206(L) x 52(W) x 300(H)mm
- Material : Brass
- Finishing : Chrome
- Water inlet size : G1/2"
- Operating water pressure : 1.5 -5 bars (dynamic)
- Water stream : Aerated



Model Code

W2-R-MXB8701X

Code	WELS	Water flow rate (l/min)	WELS registration no.	Registration country
W2-R-	✓✓	Nominal 2	<ul style="list-style-type: none"> • MXB8701X : BST-2020/030483/SLS • MXB8701X-BM : BST-2020/030484/SLS • MXB8701X-BZ : BST-2020/030485/SLS • MXB8701X-BZP : BST-2020/030486/SLS • MXB8701X-GP : BST-2020/030487/SLS • MXB8701X-GM : BST-2020/030488/SLS • MXB8701X-RG : BST-2020/030489/SLS • MXB8701X-RGP : BST-2020/030490/SLS 	SG
RL-	N.A	2 - 6 configurable	N.A	N.A

Code	Available Colour & Finishes	
(NIL)	Chrome	
-BM	Black Matte	
-BZ	Bronze Matte	
-BZP	Bronze Polished	
-GP	Gold Polished	
-GM	Gold Matte	
-RG	Rose Gold Matte	
-RGP	Rose Gold Polished	

Rev	0.1
Date	29.10.2020

DISCLAIMER : While every effort has been made to ensure factual accuracy, the information presented is subject to changes due to requirements in different sites, markets and / or countries. Rigel reserves the right to make the necessary amendments at any time without prior notice.

Technical Drawing

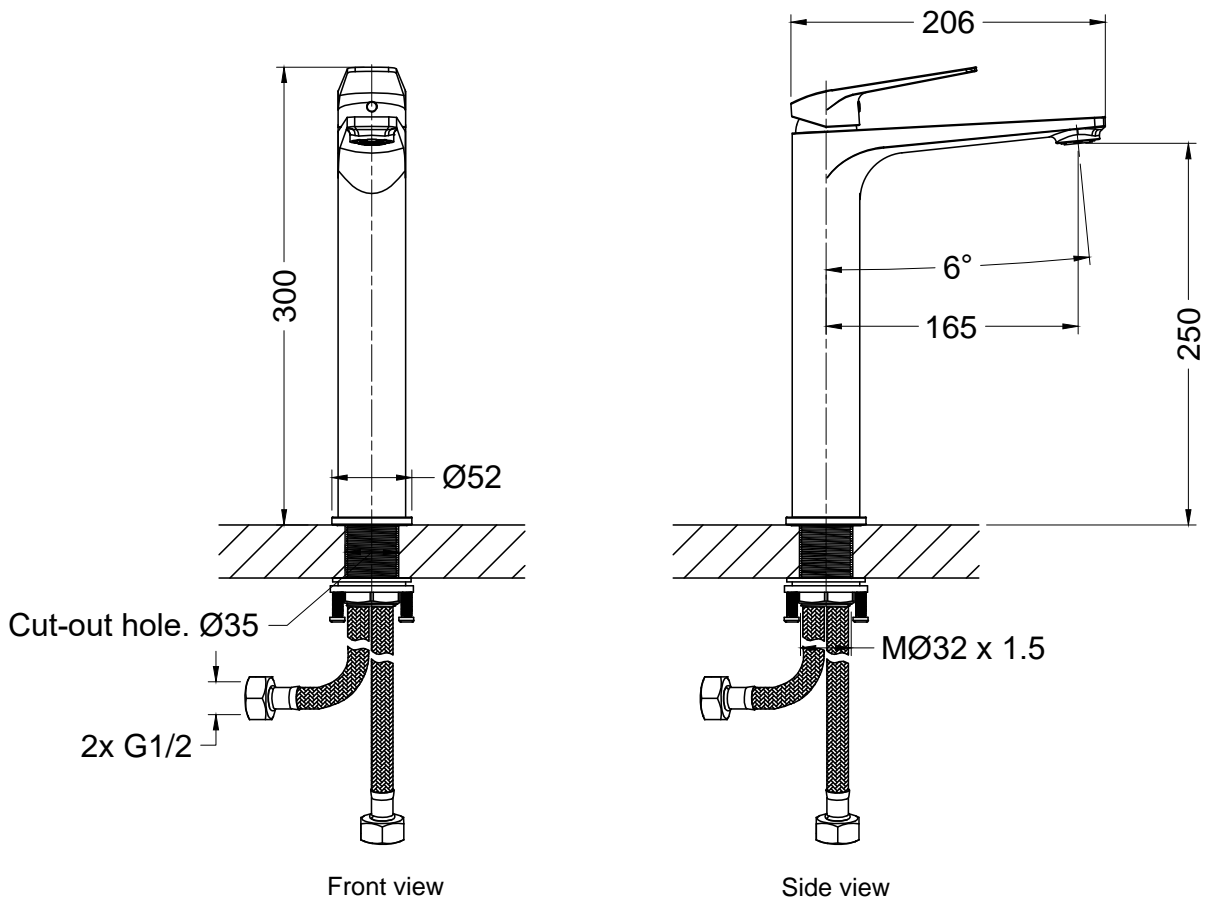

() Denotes recommended value.
All dimension are in mm.

Copyright © Rigel Technology. (S) Pte Ltd All rights reserved.

Rev	0.1
Date	29.10.2020

DISCLAIMER : While every effort has been made to ensure factual accuracy, the information presented is subject to changes due to requirements in different sites, markets and / or countries. Rigel reserves the right to make the necessary amendments at any time without prior notice.